

Main technical specifications

Model	RRun 321
Type	Vertical, water-cooling, 4-stroke, swirl combustion chamber
No. of cylinders	3
Bore (mm)	78
Stroke (mm)	78.4
Total displacement (L)	1.123
Rated power (HP)	21
Rated speed(r/min)	3000
Exhaust system	Water cooling
Lubrication method	Pressure and splash
Fuel	Diesel
Gearbox model	M30
Gearbox type	Mechanical
ratio	2:1
Net weight(kg)	135
Unit price (FOB)	

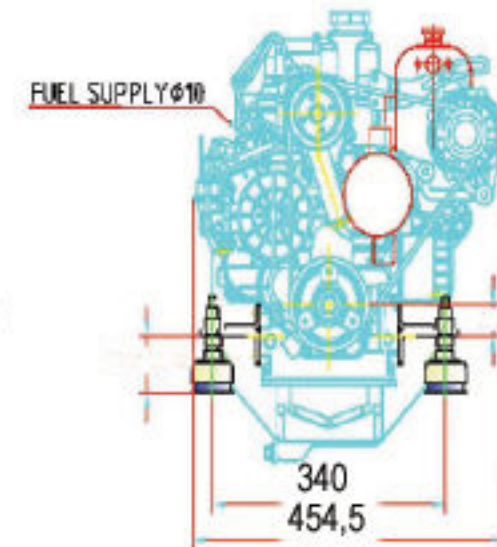
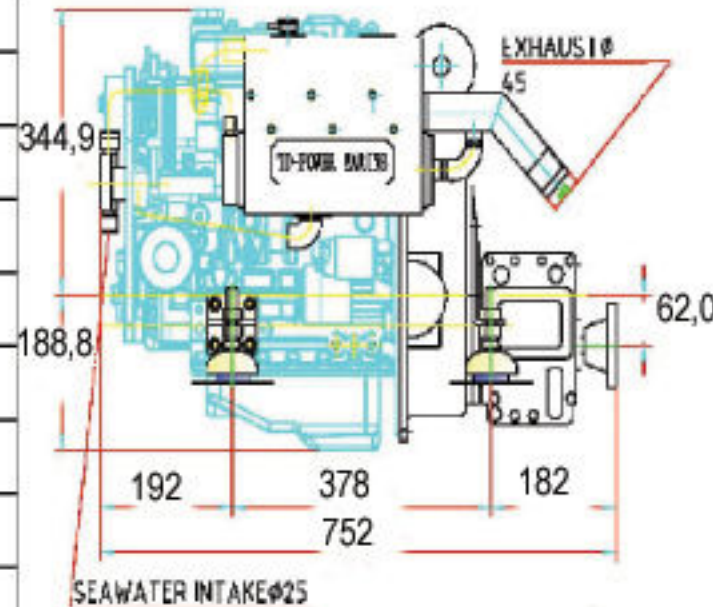
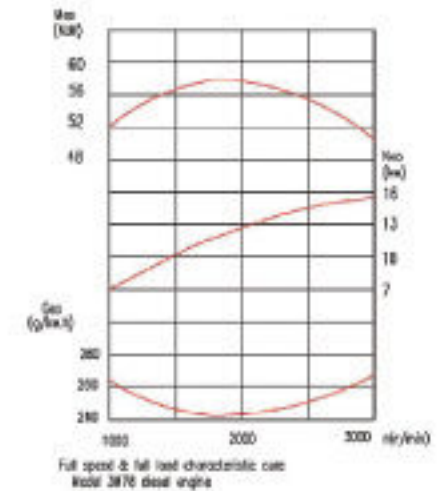

RRun 321 by Polarpod AB